



Model number

ACX04-F99-I-V15

1 axis acceleration sensor

Features

- E1-Type approval
- Analog output 4 mA ... 20 mA
- Fixed evaluation limits
- High shock resistance
- Teachable zero point
- Measuring range -2 g ... +2 g
- Increased noise immunity 100 V/m

Diagrams

Frequency response

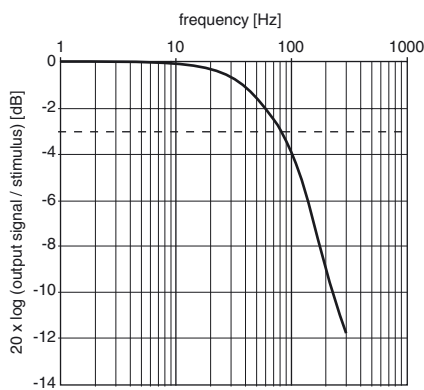

Electrical connection

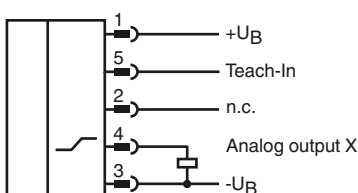

Technical Data

General specifications

Type	1 axis acceleration sensor
Measurement range	-2 ... 2 g
Resolution	≤ 5 mg
Repeat accuracy	≤ ± 5 mg
Frequency range	0 ... 100 Hz

Functional safety related parameters

MTTF _d	304 a
Mission Time (T _M)	20 a
Diagnostic Coverage (DC)	0 %

Indicators/operating means

Operation indicator	LED, green
Teach-In indicator	LED, yellow

Electrical specifications

Operating voltage U _B	10 ... 30 V DC
No-load supply current I ₀	≤ 25 mA
Time delay before availability t _v	≤ 100 ms

Analog output

Output type	1 current output 4 ... 20 mA
-------------	------------------------------

Zero signal	12 mA
Slope of output characteristic	4 mA / g
Linearity error	± 1.2 %
Load resistor	0 ... 200 Ω at U _B = 10 ... 18 V 0 ... 500 Ω at U _B = 18 ... 30 V

Temperature influence	
Offset	≤ ± 4 μA / K
Slope	≤ ± 20 μA / g

Ambient conditions

Ambient temperature	-40 ... 85 °C (-40 ... 185 °F)
Storage temperature	-40 ... 85 °C (-40 ... 185 °F)

Mechanical specifications

Connection type	5-pin, M12 x 1 connector
Housing material	PA
Degree of protection	IP68 / IP69K
Mass	240 g

Compliance with standards and directives

Standard conformity	
Shock and impact resistance	100 g according to DIN EN 60068-2-27
Standards	EN 60947-5-2:2007 IEC 60947-5-2:2007

Approvals and certificates

UL approval	cULus Listed, Class 2 Power Source
CSA approval	cCSAus Listed, General Purpose
CCC approval	CCC approval / marking not required for products rated ≤36 V
E1 Type approval	10R-04

EMC Properties

Interference immunity in accordance with
DIN ISO 11452-2: 100 V/m

Frequency band 20 MHz up to 2 GHz

Mains-borne interference in accordance with ISO 7637-2:

	1	2a	2b	3a	3b	4
Pulse						
Severity level	III	III	III	III	III	III
Failure criterion	C	A	C	A	A	C

EN 61000-4-2: CD: 8 kV / AD: 15 kV

Severity level IV IV

EN 61000-4-3: 30 V/m (80...2500 MHz)

Severity level IV

EN 61000-4-4: 2 kV

Severity level III

EN 61000-4-6: 10 V (0.01...80 MHz)

Severity level III

EN 55011: Klasse A

Dimensions

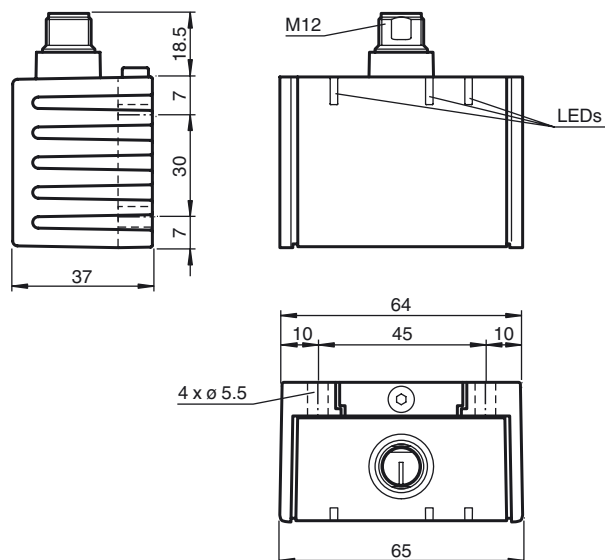

Pinout

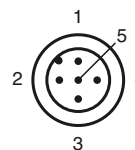

Wire colors in accordance with EN 60947-5-2

1	BN	(brown)
2	WH	(white)
3	BU	(blue)
4	BK	(black)
5	GY	(gray)

Accessories

V15-W-2M-PUR

Female cordset, M12, 5-pin, PUR cable

V15-G-2M-PUR

Female cordset, M12, 5-pin, PUR cable

Installation orientation

On delivery, the zero position of the sensor axes is achieved when the sensor is mounted flat on a horizontal plane and the electrical connection of the sensor points horizontally sideways.

LED display

Displays dependent on the operating state	LED green: Power	LED yellow 1	LED yellow 2
Normal operation	on	off	off
Teach In of reference point			
Teach In (Pin 5 connected to +U _B) for 1 s ... 10 s	on	on	off
falling slope at Teach In input	on	flashes 3 x	off
then sensor returns to normal operation.	on	off	off
Reset to factory settings:			
Teach In (Pin 5 connected to +U _B) for 20 s ... 25 s	on	on	off
falling slope at Teach In input	on	flashes 3 x	flashes 3 x
then sensor returns to normal operation.	on	off	off
Undervoltage	flashes	off	off

Factory settings

see Technical Data

Teach-in of reference point (output S1)

1. Move sensor to reference position
2. Apply supply voltage (+U_B) to Teach In input (Pin 5) for 1 s ... 10 s
3. Teach In LED lights up for confirmation
4. Disconnect Teach In input (Pin 4) before the 10 s time elapses
5. Teach In LED flashes 3 x for confirmation
6. Reference point is now programmed and the sensor returns to normal operation (see LED display)

Resetting the sensor to factory settings

1. Apply supply voltage (+U_B) to Teach In input (Pin 5) for 20 s ... 25 s
2. Teach In LED lights up for confirmation
3. Disconnect Teach In input (Pin 4) before the 25 s time elapses
4. Teach In LED and Out LED flash 3 x for confirmation
5. The sensor is now reset to factory settings and returns to normal operation (see LED display)

Undervoltage detection

If the supply voltage falls below a value of approx. 7 V, all outputs and yellow LEDs are deactivated. The green "power" LED flashes rapidly. If the supply voltage rises above a value of approx. 8 V, the sensor continues with normal operation.

Mounting of the sensor

Sensors from the -F99 series consist of a sensor module and accompanying cast aluminum housing. Select a horizontal flat surface with minimum dimensions of 70 mm x 50 mm to mount the sensor.

Mount the sensor as follows:



1. Loosen the central screw under the sensor connection.
 2. Slide back the clamping element until you are able to remove the sensor module from the housing.
 3. Remove the sensor module from the housing
 4. Position the housing at the required mounting location and secure using four countersunk screws. Make sure that the heads of the screws do not protrude.
 5. Place the sensor module in the housing.
 6. Slide the clamping element flush into the housing. Check that the sensor element is seated correctly.
 7. Finally tighten the central screw.
- The sensor is now mounted correctly.